

General information

Cavity

Type series: Cavity C0420

Dimensions and sectional view

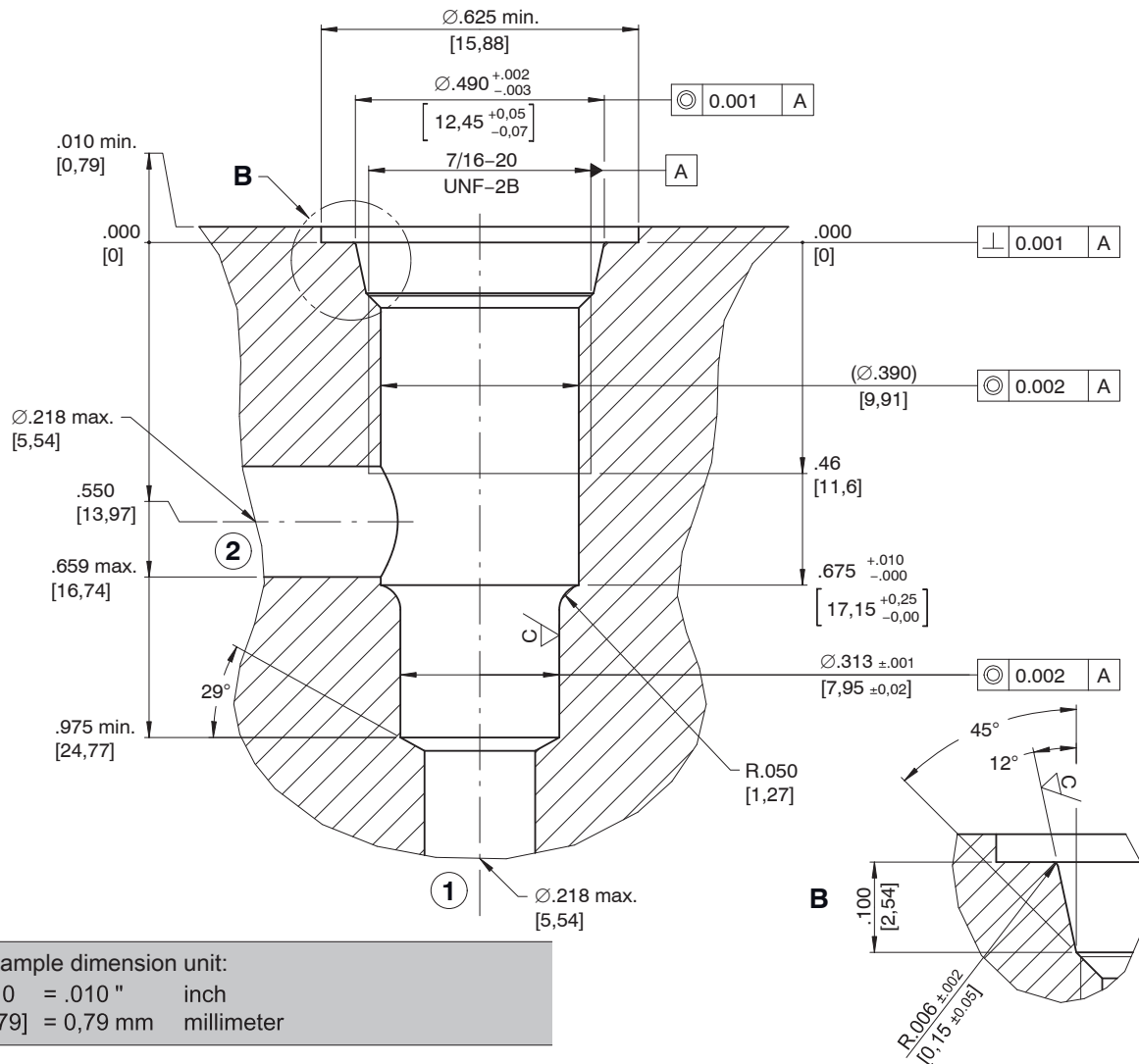

Dimension Tolerances	
Unless otherwise specified	
0.000	$\pm .005''$
0.00	$\pm .010''$
Angles	$\pm 1/2^\circ$

Surface roughness		
	∇C	∇D
Ra	45 μin	125 μin
	(1.15 μm)	(3.2 μm)
	∇D	Unless otherwise specified

Installation information

**ATTENTION!**

You must maintain the specified positional and diametral tolerances. To ensure trouble-free operation of the screw-in cartridges, we strongly recommend that pilot drilling, boring, reaming and cavity thread-cutting are always performed in one setup.

**NOTE!**

Cavity type to factory standard.

**NOTE!**

We offer form tool sets for sale or hire. See data sheet 520-P-000050 for further information.